

# FLOWLINE EQUIPMENT

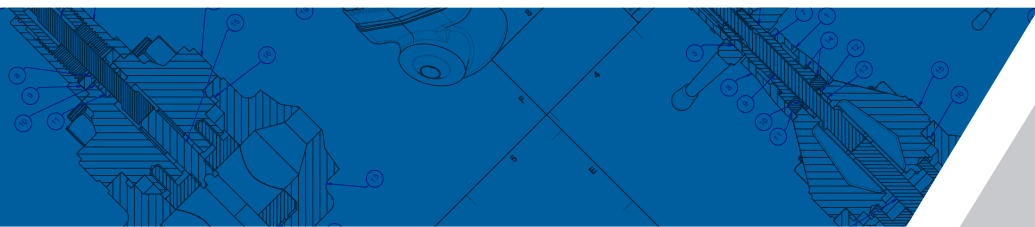

  
**PREMIUM**<sup>®</sup>  
Oilfield Technologies

Premium Oilfield Technologies has been supplying flowline equipment to the oil and gas industry since 2003. We understand the importance of safely getting the mud from pumps to the drillpipe and have developed a line of flowline products to assist the driller in making this happen.



### **INDUSTRY-STANDARD AND FULLY INTERCHANGEABLE PARTS AND SYSTEMS**

Premium MR-75 mud valves are compatible with the Cameron-Demco style. Our MR-75f mud valves are compatible with the Forum style and our MH-150 Plug Valve is compatible with the Halliburton style. All Premium parts are made to be completely interchangeable on a part-to-part and unit-to-unit basis with the OEM equivalents.

### **TRACEABILITY**

All of our valves are serialized for full traceability. MTRs and pressure test charts are available upon request.

### **INVENTORY**

We maintain high inventory levels at Premium Oilfield Technologies headquarters and multiple field locations to support our customers.

NO  
TIME  
FOR  
DOWNTIME





# CONTENTS

## MR-75

1.5" & 2" BORE 7,500 PSI	4-5
3" & 4" BORE 7,500 PSI	6-7
5" BORE 7,500 PSI	8-9

## MR-75f

3" BORE 7,500 PSI	10-11
4" BORE 7,500 PSI	12-13

## MH-150

Plug Valves & Kits	14
--------------------	----

Cameron, Demco, Forum, Halliburton, and the product models referenced in this brochure, are trademarks or registered trademarks of their respective companies. Premium Oilfield Technologies is not authorized by or affiliated with any of these companies, and no business relationship, affiliation, or endorsement is claimed or implied.

# MR-75 High Pressure Mud Valve

1.5" Bore x 2" XXH Weld End

2" Bore x 2" XXH Weld End

2" Bore x 2-1/16" 10K Flanged End

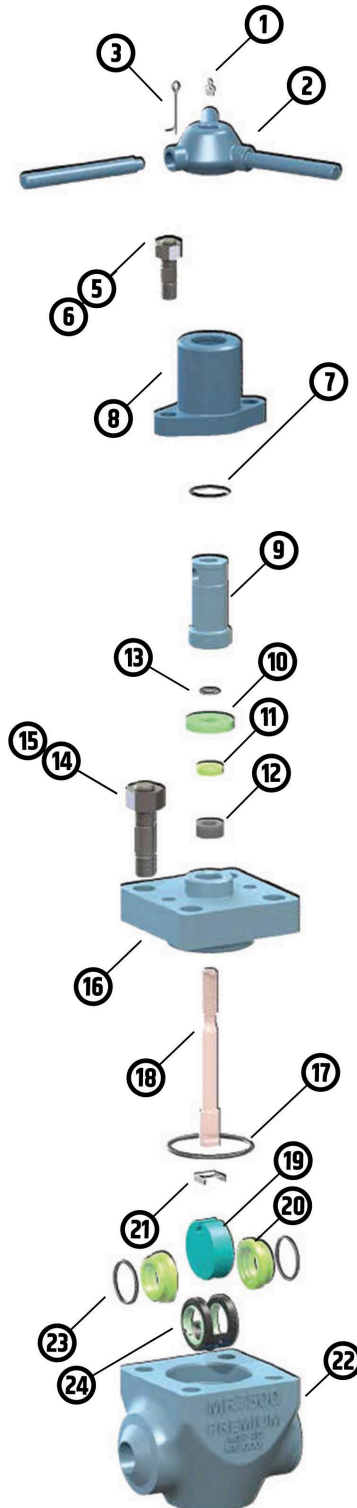
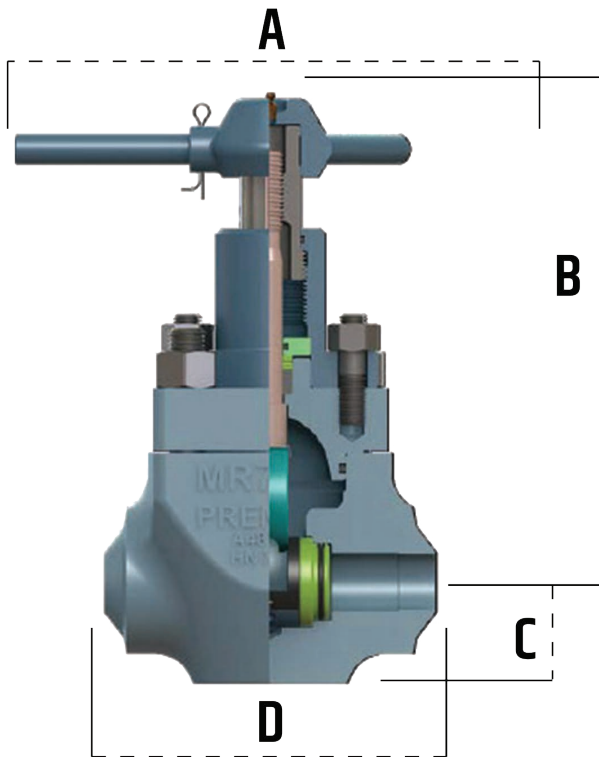

DIM	1.5" Bore XXH	2" Bore XXH	2" Bore Flanged	2" Bore 1502
A	13.88	13.88	13.88	13.88
B	13.11	13.11	13.11	13.11
C	2.75	2.75	2.75	2.75
D	9	9	20.5	15.72



# Gate Valve Components

Item No.	Part Description	Repair Kit	1.5" BORE (2" XXH)	1.5" BORE (2" XXH) - OEM	2" BORE (2" XXH)	2" BORE (2" XXH) - OEM
	Assembly-Weld End		501-0010	J025196*	501-0200	J024993*
	Assembly-Flange End		N/A	N/A	501-0210	
	Assembly-1502 End		N/A	N/A	501-0224	
	Repair Kit - Minor, includes - X		501-0070	J025177-01574	501-0440	J025177-00274
	Repair Kit - Major, includes - Y		501-0080	J025177-11574	501-0450	J025177-10274
1	Grease Fitting, 1/8 NPT		601-0009	J005195	601-0009	J005195
2	Handle		501-0230	2139712-01	501-0230	2139712-01
3	Cotter Pin		601-0037	J005420-18728	601-0037	J005420-18728
4	Handle Lock		501-0240	J001891	501-0240	J001891
5	Stud-Screw Housing		501-0410	J002066	501-0410	J002066
6	Nut-Screw Housing		210-009	2709000-08-01	210-009	2709000-08-01
7	Screw Housing Seal, HNBR	Y	3N7-2224	J005526-224	3N7-2224	J005526-224
8	Screw Housing, 1040		501-0270	J024982	501-0270	J024982
9	Stem Screw, 1040	Y	501-0250	J001913	501-0250	J001913
10	Packing Retainer		501-0300	J001940*	501-0300	J001940*
	Stem Seal Assembly, HNBR (11, 12)		501-0310	STEM SEAL ASSM. J023231-008	501-0310	STEM SEAL ASSM. J023231-008
11	Stem Bushing, AL-BR	Y	501-0311		501-0311	
12	Stem Seal Packing, FEPM	XY	501-0312**		501-0312**	
13	Secondary Seal, HNBR	Y	3H9-2210	2712425-13	3H9-2210	2712425-13
14	Stud-Body, ASTM A193 B7		501-0430	J015432	501-0430	J015432
15	Nut-Body, ASTM A194 2H		210-013	2709000-10-01	210-013	2709000-10-01
16	Bonnet, 4130		501-0350	J024895-030	501-0350	J024895-030
17	Bonnet Seal, HNBR	XY	3H9-2343	2712425-60	3H9-2343	2712425-60
18	Stem, 410SS QPQ	Y	501-0280	J024983-107	501-0290	J024983-107
19	Gate, 410SS QPQ	XY	501-0040	2269412-01*	501-0370	2139624-02
20	Body Wear Ring, 410SS QPQ	XY	501-0020	2269414-01	501-0330	2139647-02
21	Gate Clip, SS	XY	501-0320	M450480	501-0320	M450480
22	Body-Flange End, A487 4D		N/A	N/A	501-0380	N/A
	Body-Weld End, A487 4D		501-0050	N/A	501-0382	N/A
23	Wear Ring Seal, HNBR	XY	3H9-2225	2712425-18*	3H9-2225	2712425-03
24	Seat, 410SS/HNBR	XY	501-0060	2269403-01	501-0390	2139742-01

**NOTE:**

All Premium valves are hydrostatically tested: stem seal, body, and seat are inspected for zero leakage under pressure. Hydro test specifications are based upon API-6A latest edition testing requirements.

\*OEM materials may vary/part number may vary

\*\*Premium uses a higher grade elastomer, FEPM, in our stem packing than what is provided by the OEM. The typical OEM stem packing only holds pressures to 10,000 psi, whereas Premium's stem packing is certified for 15,000 psi from 10°F to 450°F.

\*\*\* Major Repair Kits, Stems, and Seat Screws are only interchangeable with old style Demco 7500 valve internals produced prior to 2018.

# MR-75 High Pressure Mud Valve

- 3" Bore x 3" XXH Weld End
- 3" Bore x 3-1/16" 10K Flanged End
- 4" Bore x 5" XXH Weld End
- 4" Bore x 4-1/16" 10K Flanged End

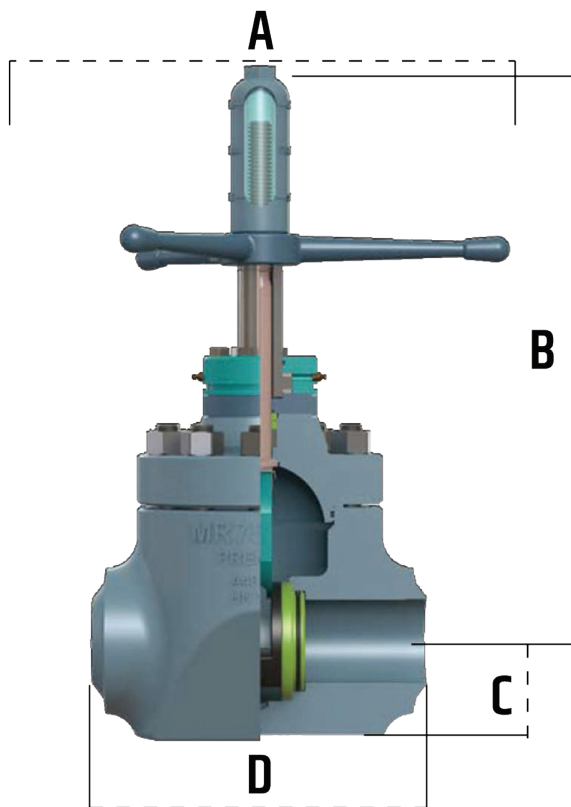

DIM	3" Bore XXH	3" Bore Flanged	4" Bore XXH	4" Bore Flanged	4" Bore 1002
A	24	24	24	24	24
B	24.6	24.6	27.54	27.54	27.54
C	3.38	3.38	4.5	4.5	4.5
D	13	24.38	16	26.38	23.13

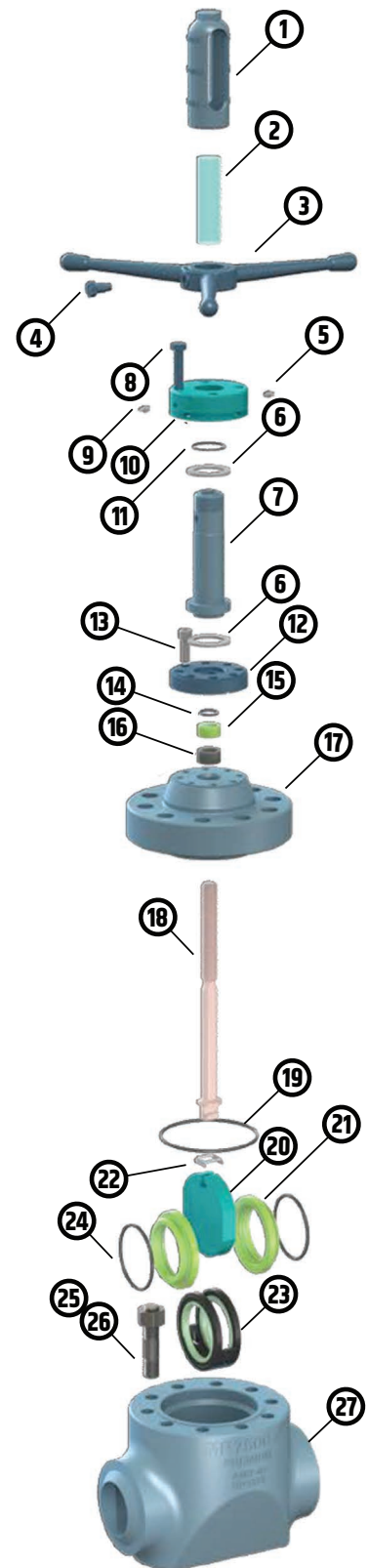

# Gate Valve Components

Item No.	Part Description	Repair Kit	3" BORE (3" XXH)	3" BORE (3" XXH) - OEM	4" BORE (5" XXH)	4" BORE (5" XXH) - OEM
	Assembly-Weld End		501-0520	J025051*	501-0850	J025100
	Assembly-Flange End		501-0530		501-0860	
	Assembly-1002 End		N/A		501-0870	
	Repair Kit - Minor, includes - X		501-0770	J025177-00374	501-1120	J025177-00474
	Repair Kit - Major, includes - Y		501-0780	J025177-10374	501-1130	J025177-10474
1	Stem Cap		501-0750	J007411	501-0920	J015855
2	Stem Tube		501-0560	J007459	501-0910	J012852
3	Hand Wheel		501-0550	2139481-01	501-0890	J015334
4	Hand Wheel Key/Screw	Y	501-0580	J05305-10016	501-0900	J014832
5	Relief Fitting, 1/8 NPT		N/A	N/A	601-0025	J051971
6	Bearing		N/A	J007426	601-0033	STEM SCREW W/BEARINGS J0023888
7	Stem Screw, 1040	Y	501-0590	J007416	501-0940	
8	Bolt-Housing, SAE GR 5		204-847**	J002072*	203-1281	702500-14-00-34
9	Grease Fitting, 1/8 NPT		601-0009	J005195	601-0009	J005195
10	Screw Housing, 1040		501-0610**	J007418*	501-0960	J015332
11	Screw Housing Seal, HNBR	Y	3N7-2224	J005526-226	3N7-2228	J005526-228
12	Packing Retainer		501-0640	J007413*	501-0990	J015330*
13	Retainer Screw, SHCP		N/A	N/A	205-1057	J005665-32028
14	Secondary Seal, HNBR	Y	3H9-2214	2712425-01	3H9-2216	2726268-01
15	Stem Bushing, AL-BR	Y	501-0311	STEM SEAL ASSM. J0011951-008	501-1001	STEM SEAL ASSM. J015853-008
16	Stem Seal Packing, FEPM	Y	501-0652***		501-1002***	
17	Bonnet, 4130		501-0700**	J017289-029*	501-1050	2172523-01*
18	Stem, 410SS QPQ	Y	501-0620	J024983-107	501-0970	2140684-01
19	Bonnet Seal, HNBR	XY	3H9-2361	2712787-07	3H9-2364	2712426-11
20	Gate, 410SS QPQ	XY	501-0720	2139628-02	501-1070	2139637-02
21	Body Wear Ring, 410SS QPQ	XY	501-0680	2139648-02	501-1030	2139649-02
22	Gate Clip, SS	XY	501-1020	M450505	501-1020	M450505
23	Seat, 410SS/HNBR	XY	501-0740	2139744-01	501-1090	2139746-01
24	Wear Ring Seal, HNBR	XY	3H9-2340	2712783-03	3H9-2349	2712787-04
25	Stud-Body, ASTM A193 B7		501-0760	J002702	501-1110	2171976-11-01
26	Nut-Body, ASTM A194 2H		210-013	2709000-10-01	170-11A08-00	2709000-11-01
27	Body-Flanged End, A487 4D		501-0730**	N/A	501-1080	N/A
	Body-Weld End, A487 4D		501-0732**		501-1082	

NOTE: All Premium valves are hydrostatically tested: stem seal, body, and seat are inspected for zero leakage under pressure. Hydro test specifications are based upon API-6A latest edition testing requirements.

\*OEM materials may vary/part number may vary

\*\* Not interchangeable with OEM

\*\*\*Premium uses a higher grade elastomer, FEPM, in our stem packing than what is provided by the OEM. The typical OEM stem packing only holds pressures to 10,000 psi, whereas Premium's stem packing is certified for 15,000 psi from 10°F to 450°F.

\*\*\*\* 3" 7500 Major Repair Kits, Stems, and Seat Screws are only interchangeable with old style Demco 7500 valve internals under base PN: J025051.

# MR-75 High Pressure Mud Valve

5" Bore x 6" XXH Weld End

5" Bore x 5-1/8" 10K Flanged End

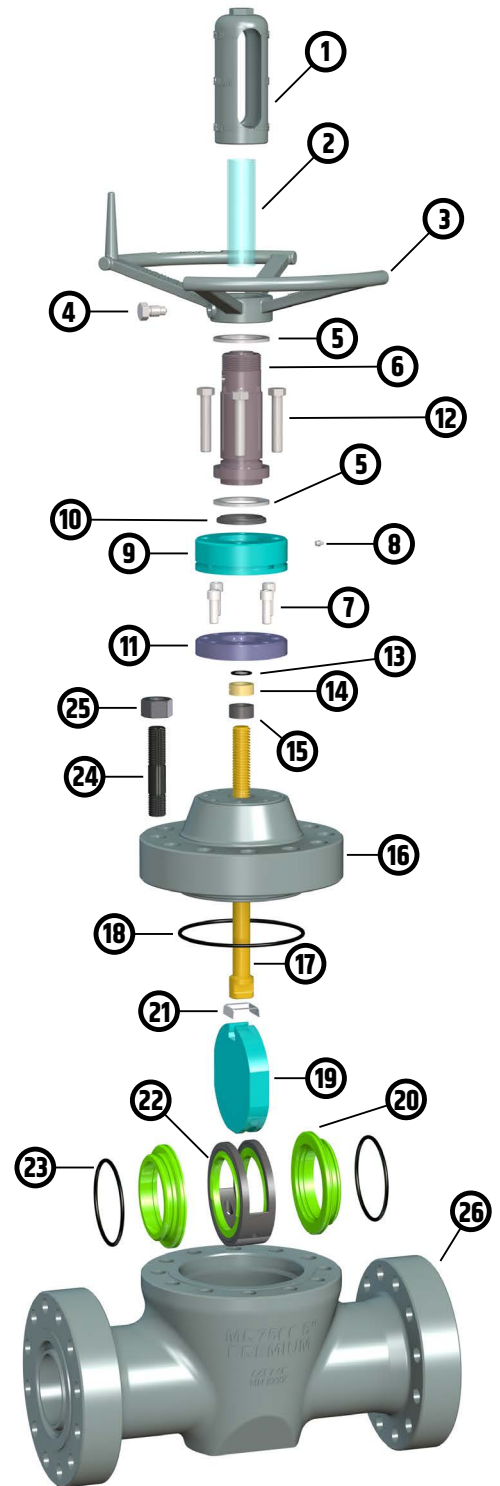
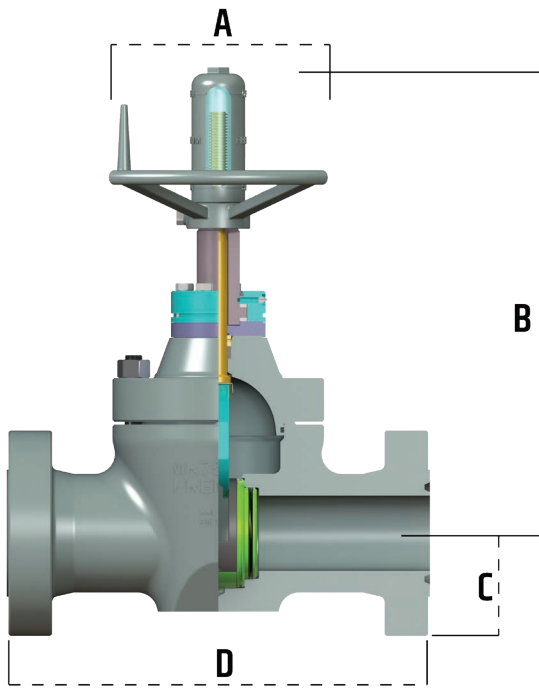

DIM	5" Weld End	5" Flanged
A	24	24
B	31.81	31.81
C	5	5
D	17.88	29

# Gate Valve Components

Item No.	Part Description	Assembly Repair Kit	5" BORE	5" BORE - OEM
	Assembly-Weld End		501-1180	J024994*
	Assembly-Flange End		501-1190	
	Repair Kit - Minor, includes - X		501-1410	J025177-00574
	Repair Kit - Major, includes - Y		501-1420	J025177-10574
1	Stem Cap		501-1240	J018193
2	Stem Tube		501-1230	J018192
3	Hand Wheel		501-1200	J016986
4	Hand Wheel Screw		501-1220	J016987
5	Bearing Assembly	Y	601-0122	STEM SCREW W/BEARINGS J023848
6	Stem Screw, 1040	Y	501-1260	
7	Bolt-Housing, SAE GR 5		205-1057	J005665-32028*
8	Grease Fitting, 1/8 NPT		601-0009	J005195
9	Screw Housing, 1040		501-1270	J018190*
10	Screw Housing Seal, HNBR	Y	601-0125	2726191-02-95
11	Packing Retainer		501-1290	J018191*
12	Retainer Screw, SHCP		202-1495	702500-16-00-40
13	Secondary Seal, HNBR	Y	3H9-2218	2712425-12
14	Stem Bushing, AL-BR	Y	501-1301	STEM SEAL ASSEMBLY J016995-008
15	Stem Seal Packing, FEPM	Y	501-1302**	
16	Bonnet, 4130		501-1350	J024956-030*
17	Stem, 410SS QPQ	Y	501-1280	J024943-107
18	Bonnet Seal, HNBR	XY	3H9-2446	2712425-78
19	Gate, 410SS QPQ	XY	501-1370	2139629-02
20	Body Wear Ring, 410SS QPQ	XY	501-1340	2139650-02
21	Gate Clip, SS	XY	501-1330	M451649
22	Seat, 410SS/HNBR	XY	501-1390	2139748-01
23	Wear Ring Seal, HNBR	XY	3H9-2435	2726268-02
24	Stud-Body, ASTM A193 B7		501-1400	2171976-12-01
25	Nut-Body, ASTM A194 2H		210-019	2709000-12-01
26	Body-Weld End, A487 4D		501-1380	N/A
	Body-Flange End, A487 4D			N/A

Note: All Premium valves are hydrostatically tested: stem seal, body, and seat are inspected for zero leakage under pressure. Hydro test specifications are based upon API-6A latest edition testing requirements.

\*OEM materials may vary/part number may vary

\*\*Premium uses a higher grade elastomer, FEPM, in our stem packing than what is provided by the OEM. The typical OEM stem packing only holds pressures to 10,000 psi, whereas Premium's stem packing is certified for 15,000 psi from 10°F to 450°F.

\*\*\* Major Repair Kits, Stems, and Seat Screws are only interchangeable with old style Demco 7500 valve internals produced prior to 2018.



# MR-75f High Pressure Mud Valve

3" Bore x 2" XXH Weld End

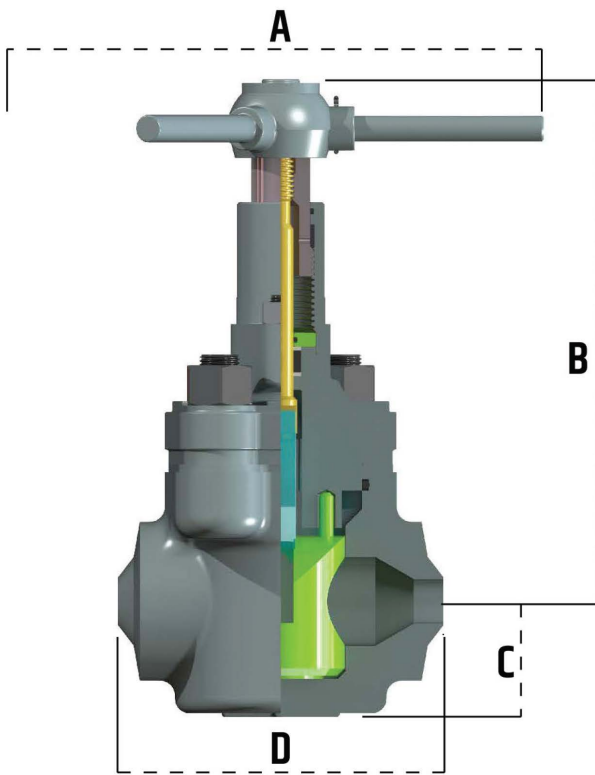

DIM	3" XXH
A	18"
B	17.685"
C	4.67"
D	11"

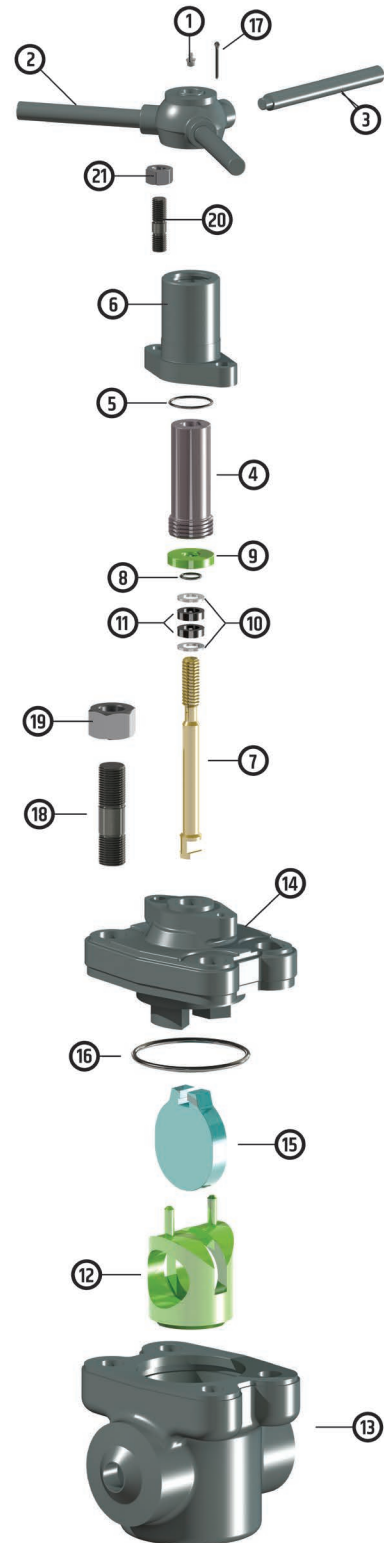

# Gate Valve Components

Item No.	Part Description	Repair Kit	3" Bore (2" XXH)	3" Bore (2" XXH) OEM
	Assembly-Weld End		501-3420	9308145J0B00
	Repair Kit - Minor, includes - X		501-3670	051965641
	Repair Kit - Major, includes - Y		501-2600	051965331
1	Lube Fitting, 1/8 NPT		601-0009	WWW00C00
2	Handle		501-3450	051888100
3	Handle Lock		501-3480	051888500
4	Stem Screw, 1040		501-3490	051883900
5	Screw Housing Seal, 2-226 NBR	Y	3N7-2226	WWB226H30
6	Screw Housing, 1040		501-3510	051884000
7	Stem, 410SS QPQ	Y	501-3520	051818708
8	Secondary Seal, 2-212 HNBR	Y	3H9-2212	WWB212H30
9	Packing Retainer, 410SS		501-3540	051883800
10	Stem Bushing ALT, Teflon	Y	501-3554	
11	Stem Seal Packing, POLYPAK	Y	601-0127	051818203
12	Seat, 410SS/HNBR	XY	501-3640	052087027
13	Body Weld End, A487 4D		501-3632	051886629
14	Bonnet, A487 4D		501-3600	052068639
15	Gate, 410SS QPQ	XY	501-3620	051950508
16	Bonnet Seal, 2-433 HNBR	XY	3H9-2433	WWB433H40
17	Cotter Pin		601-0037	WWLC16204
18	Stud, 1.375-8UN x 5.125LG		501-3660	WWHS1S2S6
19	Nut, 1.37508UN		210-022	WWJA1S10Z
20	Stud, .750-10UNC x 2.75LG		501-3650	WWHS2D586
21	Nut, .750-10UNC		210-009	WWJA2D10Z

NOTE: All Premium valves are hydrostatically tested: stem seal, body, and seat are inspected for zero leakage under pressure. Hydro test specifications are based upon API-6A latest edition testing requirements.

# MR-75f High Pressure Mud Valve

4" Bore x 5" XXH Weld End

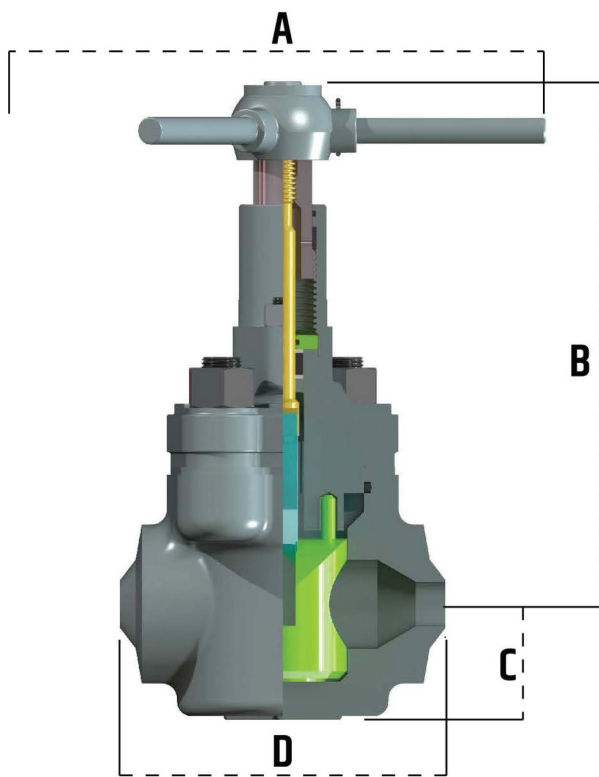

DIM	4" XXH
A	24"
B	24.393"
C	4.544"
D	13"

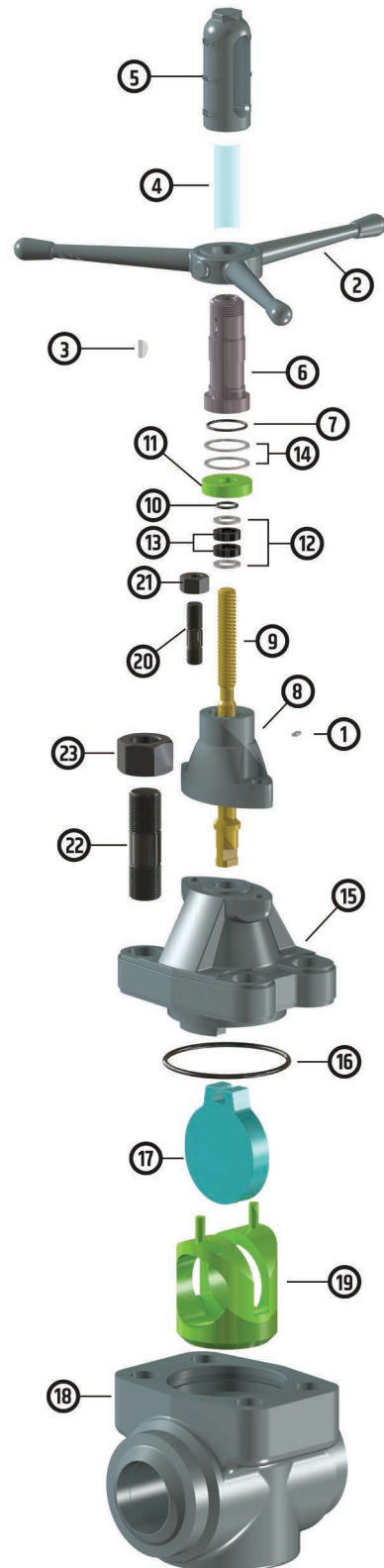

# Gate Valve Components

Item No.	Part Description	Repair Kit	4" Bore (5" XXH)	4" Bore (5" XXH) OEM
	Assembly-Weld End		501-3750	9348445J0B00
	Repair Kit - Minor, includes - X		501-4020	052089941
	Repair Kit - Major, includes - Y		501-3300	052092331
1	Grease Fitting, 1/16 NPT		601-0158	WWW00C000
2	Handwheel		501-0550	0518889600
3	Handwheel Key	Y	501-0580	WWW00A00
4	Stem Tube		501-0560	051889600
5	Stem Cap		501-0570	051889700
6	Stem Screw, 1040		501-0590	051883200
7	Screw Housing Seal, 2-226 NBR	Y	3N7-2226	WWB226H30
8	Screw Housing, 1040		501-3860	051883400
9	Stem, 410SS QPQ	Y	501-3870	0518202008
10	Secondary Seal, 2-214 HNBR	Y	3H9-2214	WWB214H40
11	Packing Retainer, 1040		501-0640	051882800
12	Stem Bushing ALT, Teflon	Y	501-3904	
13	Stem Seal Packing, POLYPAK	Y	601-0126	051819503
14	Bearing	Y	501-0660	05188300
15	Bonnet, A487 4D		501-3950	051889539
16	Bonnet Seal, 2-439 HNBR	XY	3H9-2439	WWB439H40
17	Gate, 410SS QPQ	XY	501-3970	051997709
18	Body, Weld End, A487 4D		501-3982	051999429
19	Seat, 410SS/HNBR	XY	501-3990	051820527
20	Stud, .875-9UNC x 3.375LG		501-4000	WWHS1W3H6
21	Nut, .875-9UNC		210-011	WWJA1W3H6
22	Stud, 1.75-8UN-2A x 6.000LG		501-4010	WWHS2S606
23	Nut, 1.75-9UNC-2A		210-026	WWJA2S10Z

**NOTE:**

All Premium valves are hydrostatically tested: stem seal, body, and seat are inspected for zero leakage under pressure. Hydro test specifications are based upon API-6A latest edition testing requirements.

# MH-150 High Pressure Plug Valve

2" x 1" 1502 Connections  
 2" x 2" 1502 Connections  
 3" x 3" 1502 Connections

- Rugged Construction with Forged Alloy Steel Body
- Valve Parts are Interchangeable with Most Major Brands
- Rated for 15,000 psi and Tested at 22,500 psi

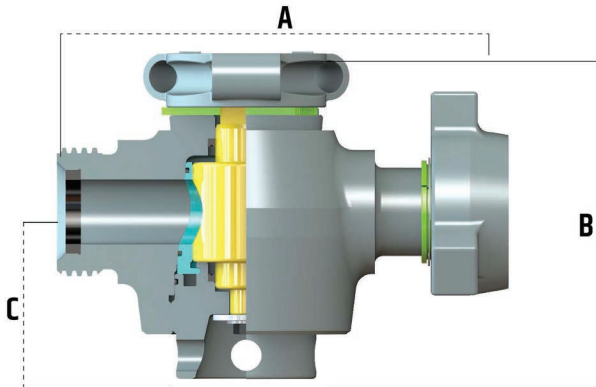
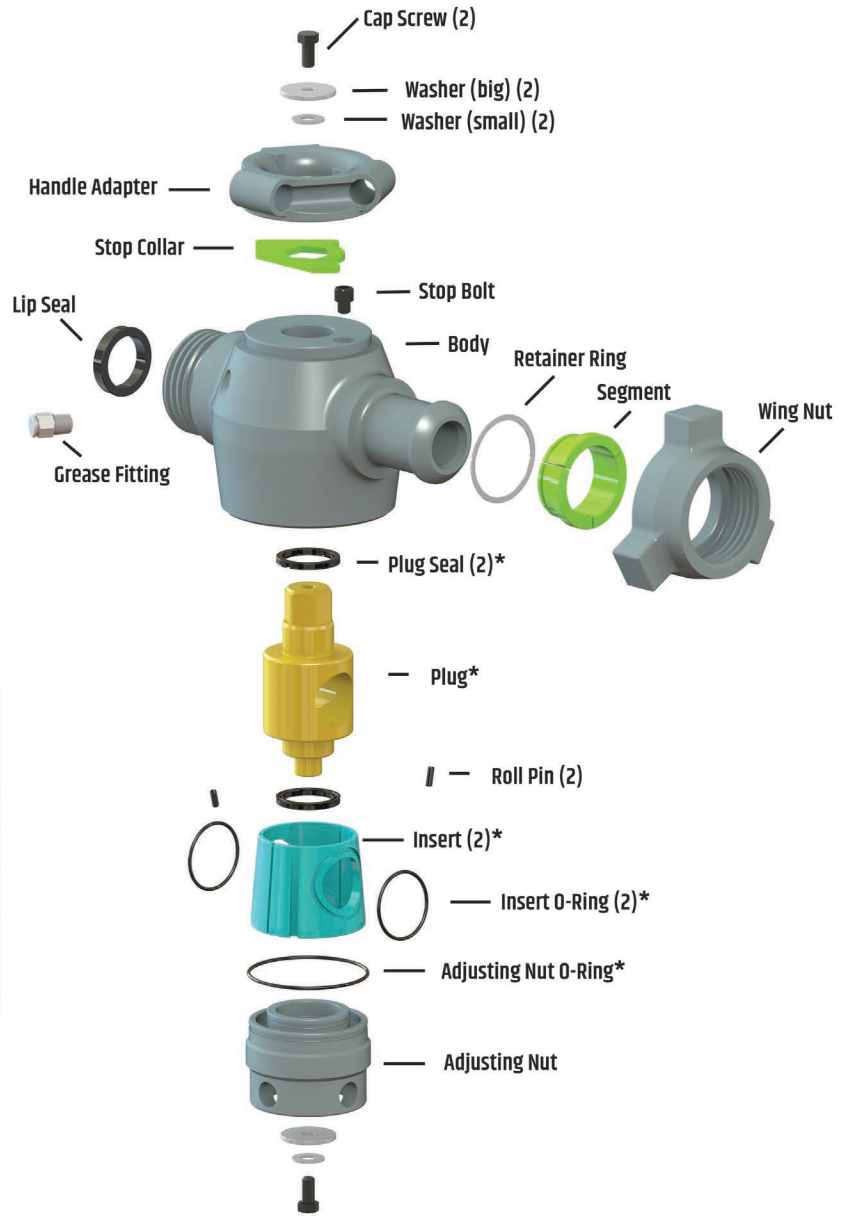

Valve	A	B	C
2" x 1"	10.53	9.24	4.74
2" x 2"	13.88	10.67	5.41
3" x 3"	17.00	18.15	7.20

	Assembly	Repair Kit *
Plug Valve 2" x 1"	505-0103	505-0102
Plug Valve 2" x 2"	505-0101	
Plug Valve 3" x 3"	505-0104	505-0105

\* Repair Kits consist of Plug Seals, Plug, Inserts, Insert O-Rings, Adjusting Nut O-ring



# Since 2003, Premium Oilfield Technologies has been supplying quality products to the oil and gas industry.

Our core focus is to provide performance enhancing solutions that meet the strictest safety standards. We have developed, tested, and enhanced mud pump components, top drives, mud valves, RCD/MPD systems, shaker screens, and other drilling products that decrease downtime, improve safety, and perform in the toughest drilling environments.

Premium Oilfield Technologies has worldwide locations and operations in all of the U.S. major shale plays. Our field locations boast a crew of experienced technical sales representatives that visit each rig several times per month. Geographic positioning allows us to directly supply our products to more than 500 drilling rigs every day.

- ◆ Industry standard, fully interchangeable parts and systems
- ◆ Performance-enhancing hammerless technology
- ◆ Time saving safety enhancements
- ◆ Field-based rig site technical support
- ◆ Managed rig site inventory 24/7/365
- ◆ Strict onsite testing and quality assurance

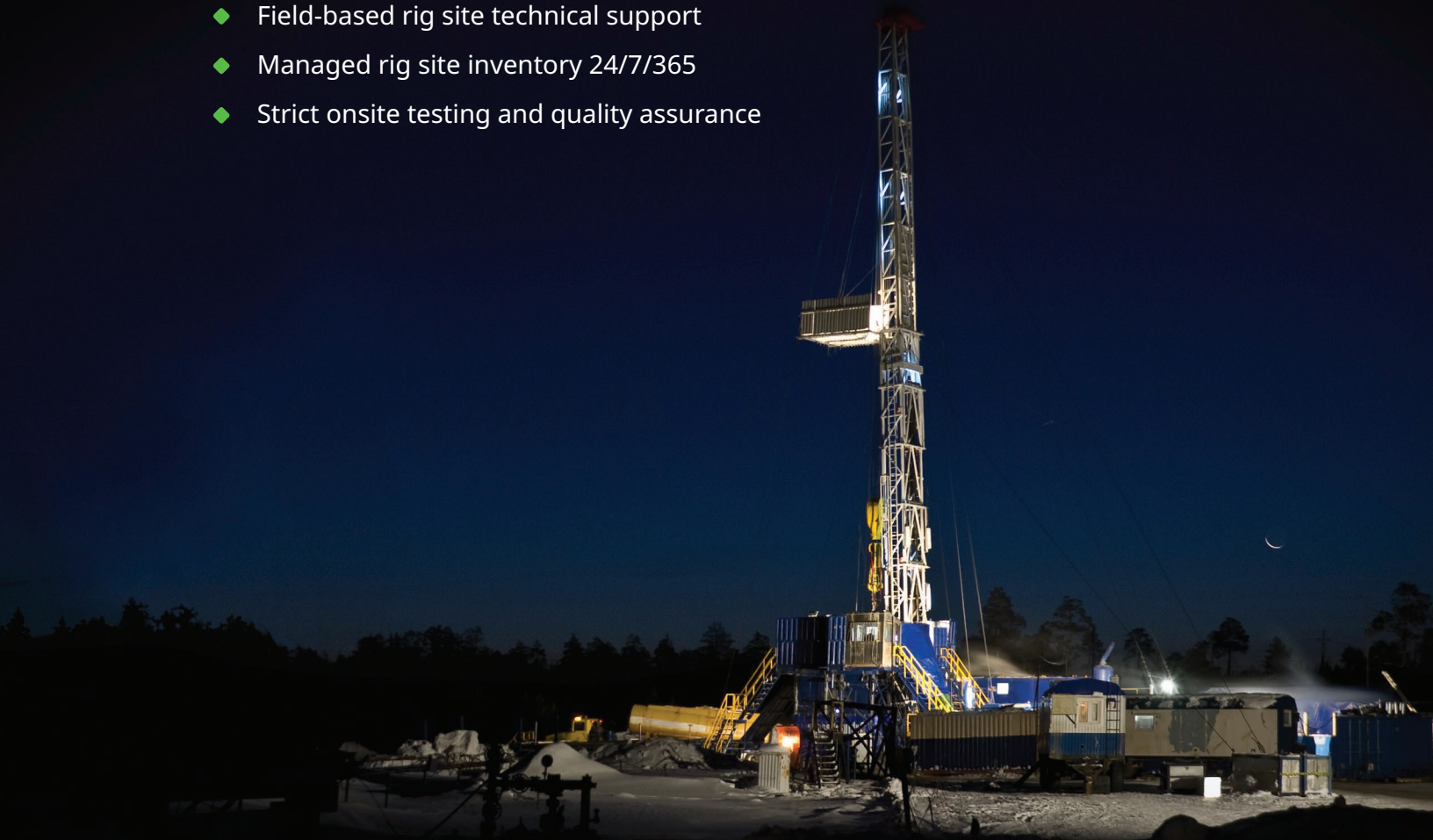

## CORPORATE

### Premium Oilfield Technologies - USA

10600 W. Sam Houston Pkwy. North  
Houston, TX 77064  
T: +1 281.670.5200

## MANUFACTURING & REPAIR

### *Premium Drilling Equipment and Support*

9841 Windmill Park Ln.  
Houston, TX 77064  
T: +1 281.670.5200

### *Patriot and Urethane*

10600 W. Sam Houston Pkwy. N.  
Houston, TX 77064  
T: +1 281.670.5228

### *West Texas Operations*

#### *All Divisions*

10207 West Industrial Ave.  
Midland, TX 79706  
T: +1 432.563.2328

### *Patriot Screens*

4602 S. MacArthur Blvd.  
Oklahoma City, OK 73179  
T: +1 405.470.6553

### *Canada Operations*

#### *All Divisions*

107-6704-41 Street  
Leduc, Alberta  
Canada T9E 0Z4  
T: +1 877.593.0034

## FIELD SALES, SERVICES AND REPAIR OFFICES

California / Colorado / Louisiana / New Mexico / North Dakota / Oklahoma / Pennsylvania / Texas / Utah / Wyoming

## INTERNATIONAL

### KUWAIT

#### Premium Oilfield Technologies

P.O. Box 721  
Yarmouk, Kuwait 72658  
T: +965 99679126  
T: +965 66022296

### UAE

#### Premium Oilfield Technologies Trading LLC

P.O. Box 89561  
Dubai, UAE  
T: +971 55 889 7210  
T: +971 56 986 3834

### INDIA

#### PMR Mud Riggers India Private Limited

S-Block-232, MIDC  
Bhosari, Pune MH 411026  
India

### UAE

#### Premium Oilfield Technologies FZE Top Drive Solutions

S700, PLOT S30229  
Jebel Ali Free Zone (South)  
P.O. Box 262263  
Dubai, UAE  
T: +971 4 889 4897  
T: +971 506587570

### SAUDI ARABIA

#### Premium Mud Pumps Trading Est.

P.O. Box 956  
Dammam, KSA  
Postal Code: 31951  
T: +966 50 0157516

### UAE

#### Premium Oilfield Technologies FZE Mud Pump Solutions

S700, PLOT S30229  
Jebel Ali Free Zone (South)  
P.O. Box 262263  
Dubai, UAE  
T: +971 4 889 4897  
T: +971 558897210



Premium Oilfield  
Technologies  
Q1-3977

[sales@premiumoilfield.com](mailto:sales@premiumoilfield.com)  
[premiumoilfield.com](http://premiumoilfield.com)